

RAMC

(REMOTE ANTENNA MOUNT CONTROLLER)

TEAM RAR:

CYRIL ACHOLO
TOLU AKINYOSOYE
IVERSON BELL
OMOLADE SALAWU

APRIL 20, 2009

WWW.MWFTR.COM

AGENDA

- ❑ Introduction
- ❑ Problem Formulation
- ❑ Solution Generation
- ❑ Solution Implementation
- ❑ Project Demonstration
- ❑ Performance Evaluation
- ❑ Suggested Future Projects
- ❑ Conclusion
- ❑ Acknowledgements

INTRODUCTION



- ❑ Wireless telephones communicate via radio waves using a system of base stations to send, receive, and relay calls to networks.
- ❑ Regions where the radio signal weakens are known as “dead zones”.
- ❑ A way to eliminate dead zones is to reposition the antenna to change the direction of the signal generated.

PROBLEM FORMULATION

- ❑ **Panel antennas are directional and must be aimed at the tower or signal coming off the tower. They have a certain angle in which they can capture/pick up the signal...**

- Lisa Calcagni, AlternativeWireless.com

- ❑ **A panel antenna focuses RF energy into one direction only... the panel antenna can be used to 'aim' for deadspots.**

- Mr. Paul M. Paul, Field Applications Engineer, Laird Technologies

- ❑ **[It] can greatly enhance the performance of a wireless network by allowing communications over distances much greater than would be possible without it.**

- Ms. Krystal C., Sprint Nextel

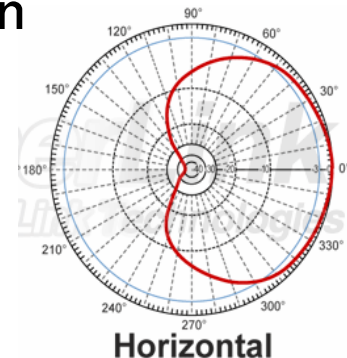
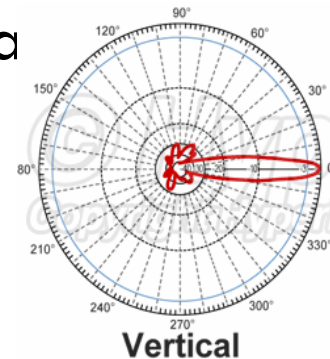

Real Antennas



Problem Statement

- ❑ Our goal: Design a small-scale model that will allow a user to adjust the azimuth and tilt of an antenna via a simple remote interface.
 - Simplicity
 - Convenience
 - Accuracy

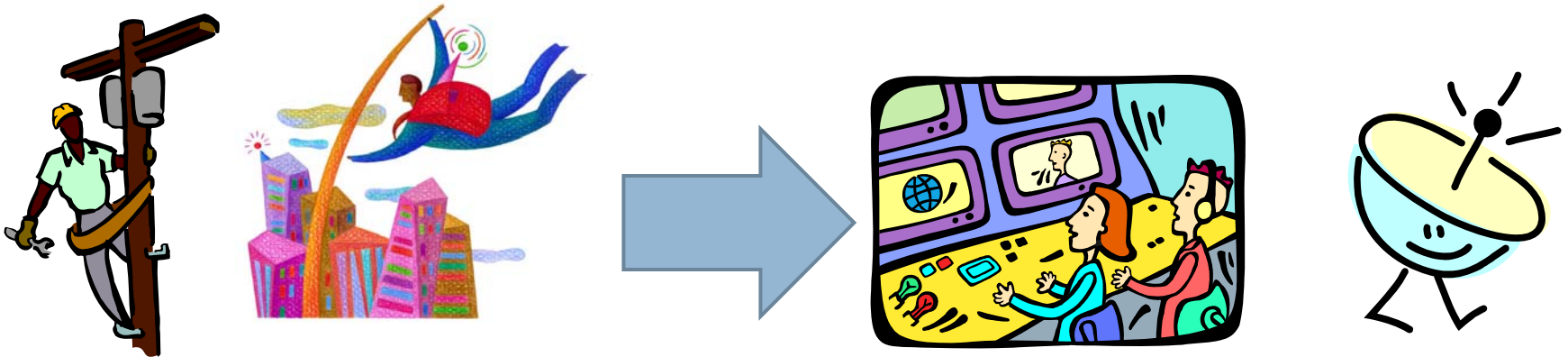

Advantages of RAR Method



Traditional Method	<i>RAR Method</i>
An engineer determines how to reposition an antenna to eliminate a dead zone	An engineer determines how to reposition an antenna to eliminate a dead zone
A technician is contacted to climb a building/tower to reach the antenna and reposition it	The RF engineer enters the change in antenna azimuth and tilt in the user interface
Antenna is turned off during positioning to protect the technician from concentrated electromagnetic radiation	N/A
The technician adjusts the antenna mount	The interface sends commands to the motors which move to position the antenna mount.
The antenna is turned back on	N/A

Design Requirements

- ❑ Accuracy within (\pm) 5 to 10 degrees
- ❑ Estimated cost of \$1,500
- ❑ Speed of 1 rev/min
- ❑ Maximum response time of 60 seconds
- ❑ Maximum weight of 30 lbs
- ❑ Compliance with
 - IEEE 1680 (RoHS)



SOLUTION GENERATION

❑ Sticks

- User interface: Play-station pad and PIC
- Purchased driving circuit and controller



❑ Keys

- User interface: Computer
- Team-designed driving circuit and controller

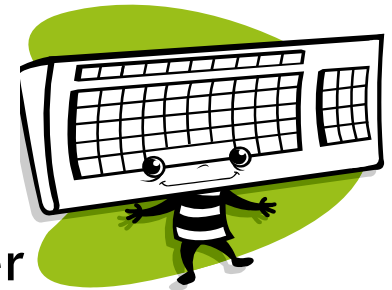

❑ Buttons

- User interface: Spartan 3E FPGA
- Team-designed driving circuit and controller



Decision Matrix

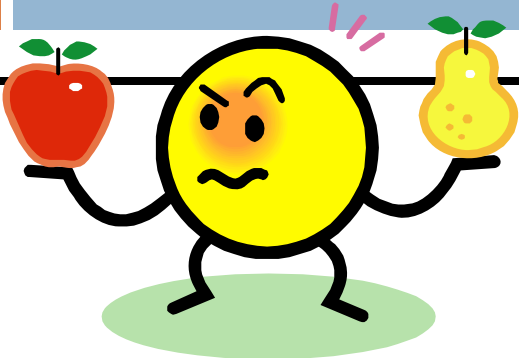

		Buttons		Sticks		Keys	
Selection Criteria	Weight	Rating	WS	Rating	WS	Rating	WS
Price	30	4	1.20	2	0.60	2	0.60
Ease of Implementation	25	4	1.00	3	0.75	2	0.50
Capabilities and Constraints	25	3	0.75	3	0.75	3	0.75
Ease of Use	30	4	1.20	4	1.20	4	1.20
Total Score		4.15		3.30		3.05	
Rank		1st		3rd		2nd	

SOLUTION IMPLEMENTATION

- ❑ Software: VHDL (Verilog Hardware Description Language)
- ❑ Hardware

- Electronic Circuits

- Current Amplifier
- Diode Bridge
- Indexer
- Heat Sink...

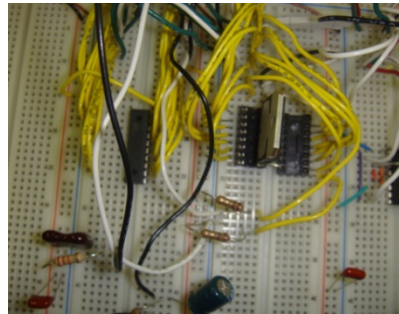

- Digital Circuitry

- ROM
- Multiplier
- Adder
- Multiplexer...

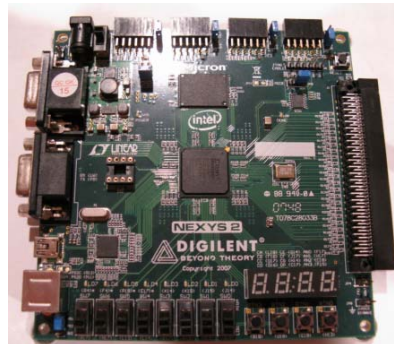

Digital Processor: Top Level

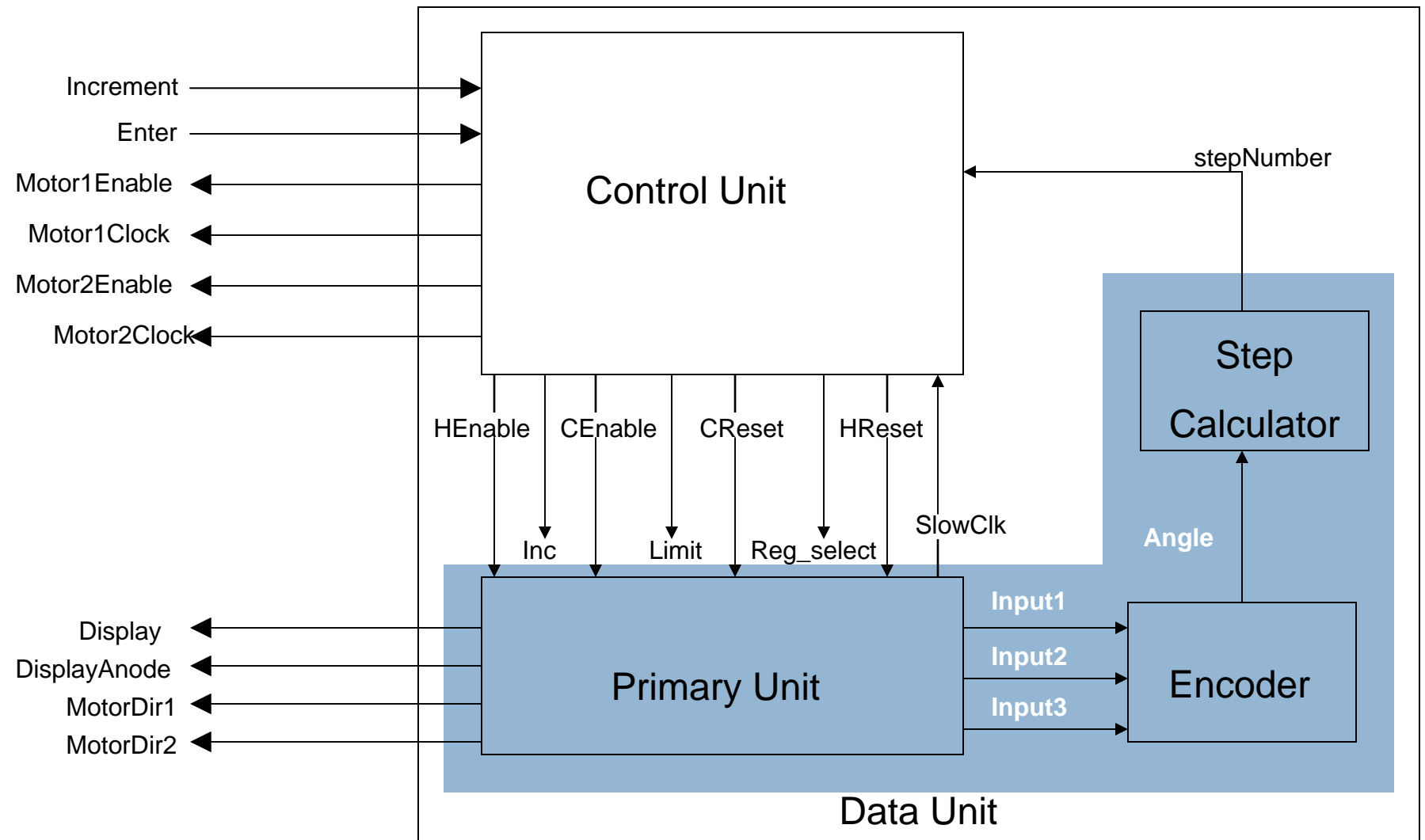

Digital Processor: Primary Unit

❑ Problem: How can simple inputs be used to control the system?

❑ Approach

- Who wants to count from 0 to 255?
- What did you want again?
- Let's adjust the antenna with our eyes closed!
- You try spinning at 50MHz!



Digital Processor: Step Calculator

- ❑ Problem: Divide an 8-bit input by 1.8 to output the required number of steps for the motor
- ❑ Constraints: The synthesis tool does not support division
- ❑ Solution
 - Converts 8-bit input from fixed point to IEEE-754 floating point representation
 - Implements 32 bit floating point division algorithm
 - Implements algorithm for rounding to nearest integer value
 - Converts output to 8 bit fixed point

Digital Processor: Control Unit

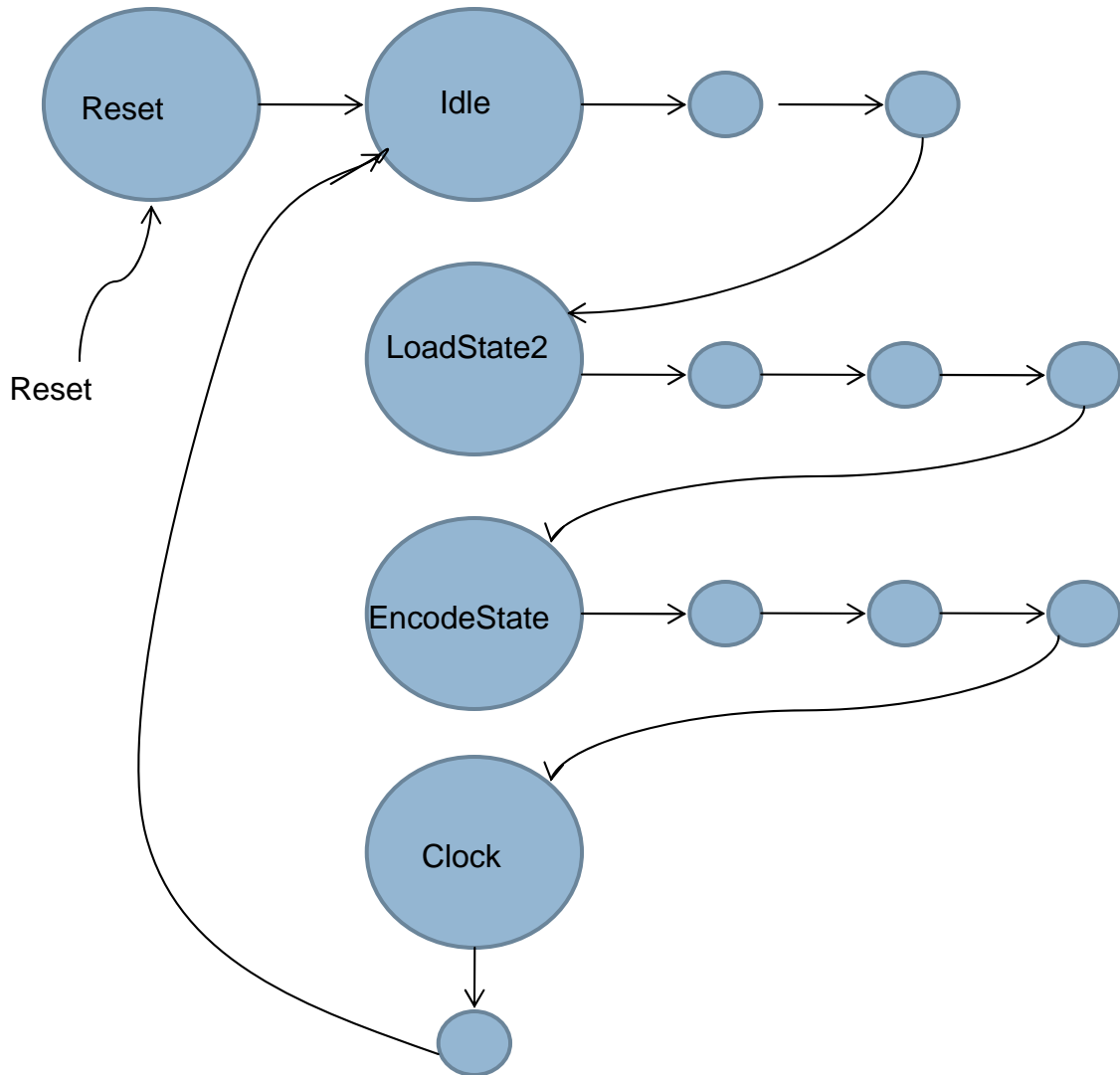

- ❑ Provides timing and control signals to Data Unit operations
- ❑ Overall operation is controlled by a system clock closely synchronized to memory cycle speed

Control System

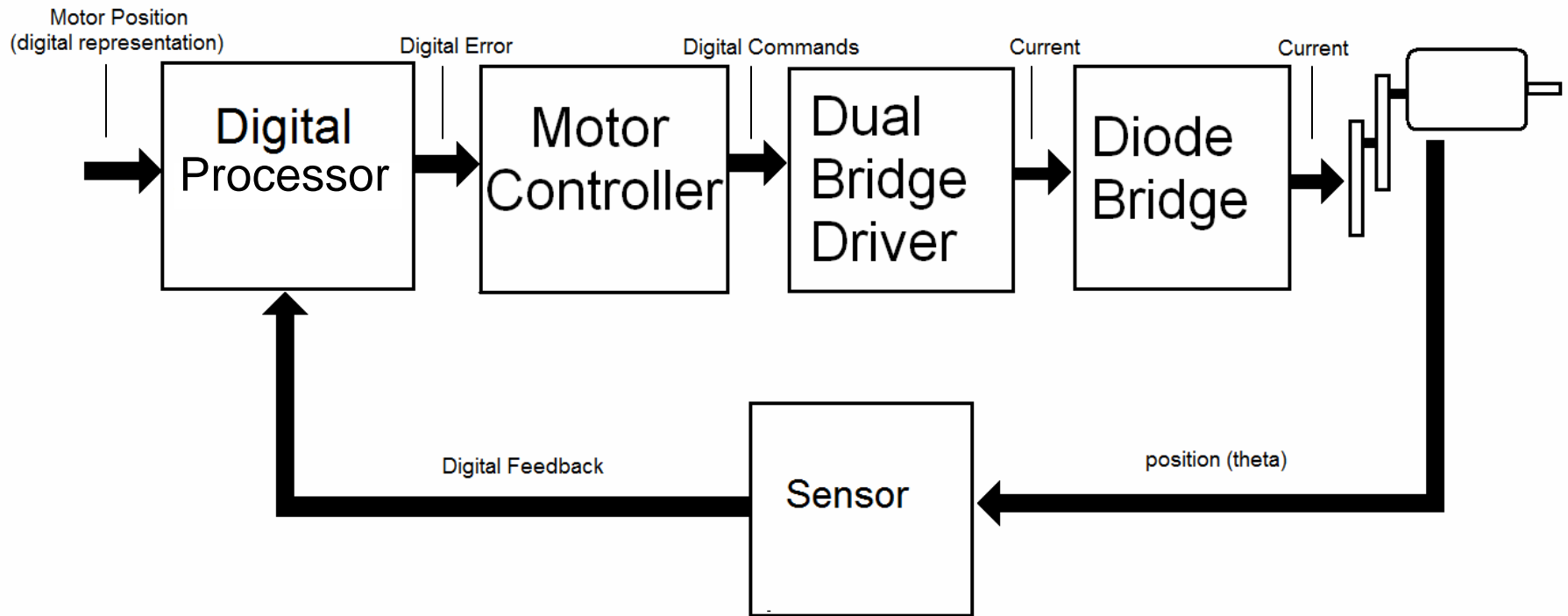

Mechanical System

- $\tau_{\text{net}} = m_t + \tau_f$

- $\tau_{\text{net}} = \left[\frac{w_{\text{cyl}}}{2g} (r_1^2 + r_2^2) + \frac{w_{\text{arm}}}{g} \left(\frac{L_{\text{arm}}}{3} + r_2^2 \right) \right] \frac{w_f}{t_f} + (w_{\text{arm}}) r \mu \sin \theta$

- $\text{Power} = \tau_{\text{net}} * \omega_f$

- High torque Bipolar stepper motor

- easy and accurate position control

- optimal for low speed and high torque performance

- Has sufficient detent torque to serve as motor brake when no current is flowing in stator windings

Driving Circuit: Top Level

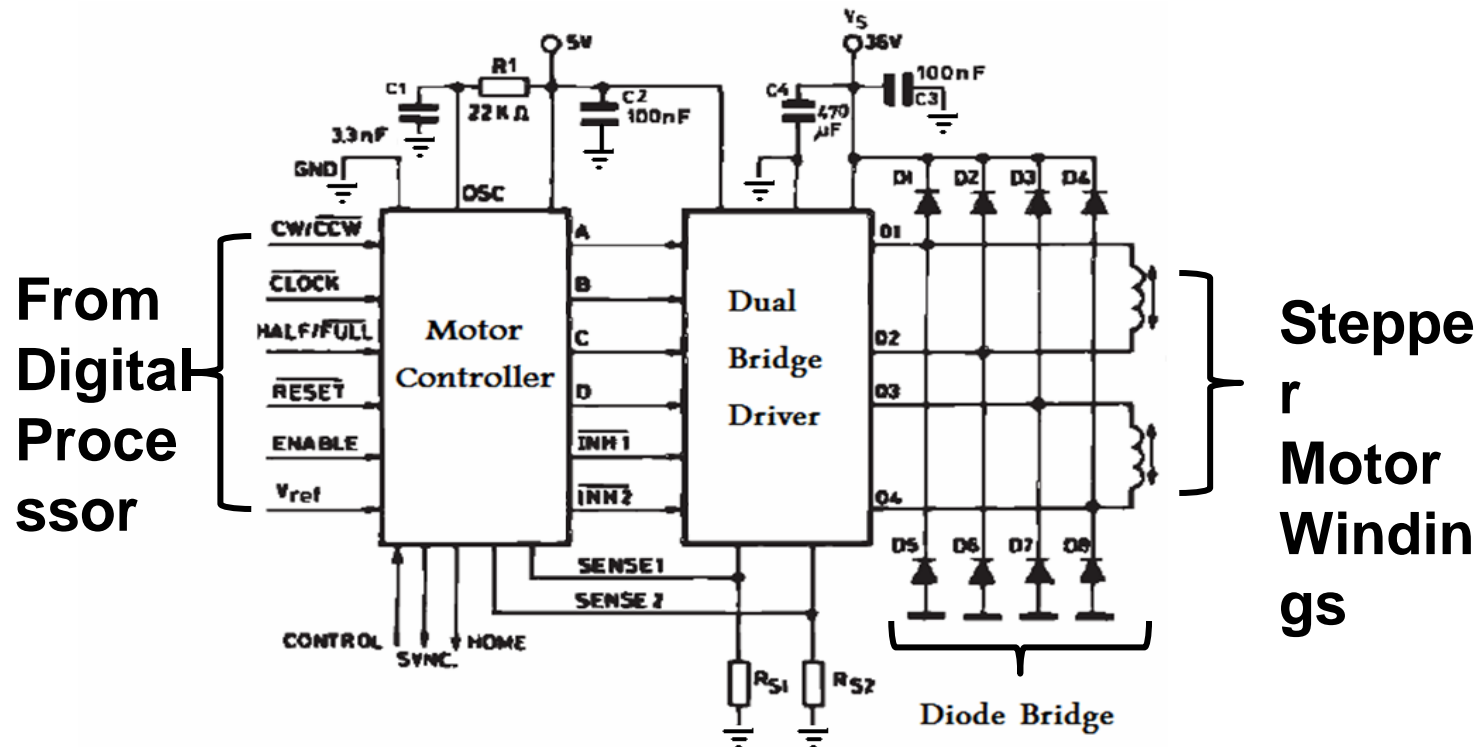

- ❑ The circuitry connecting the controller to the motor
 - Indexer: Step sequence and amplitude chopping
 - Amplifier: Current amplification for motor windings
 - Diode bridge: Indexer and amplifier protection

Driving Circuit

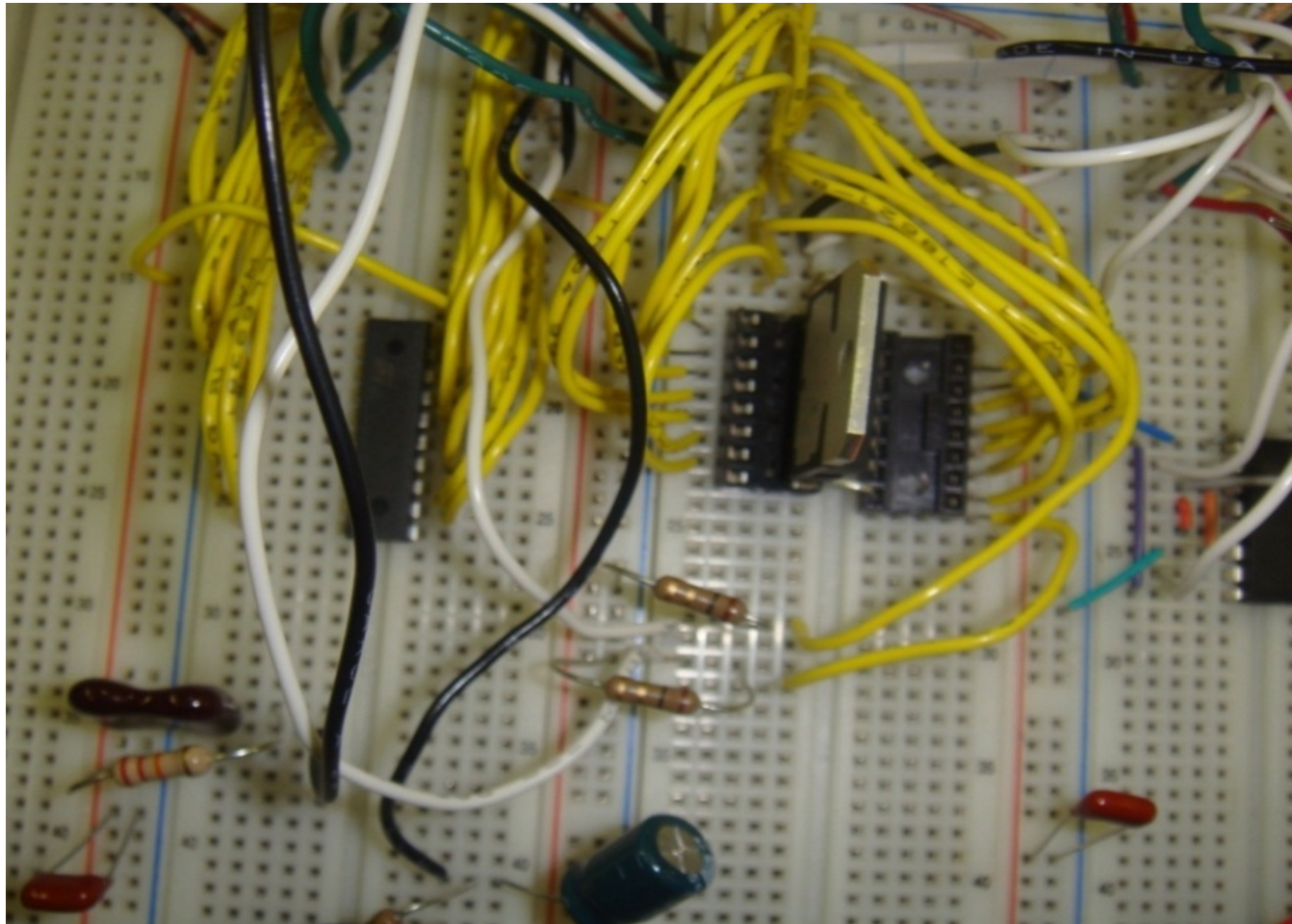

Theoretical Antenna Mount Model

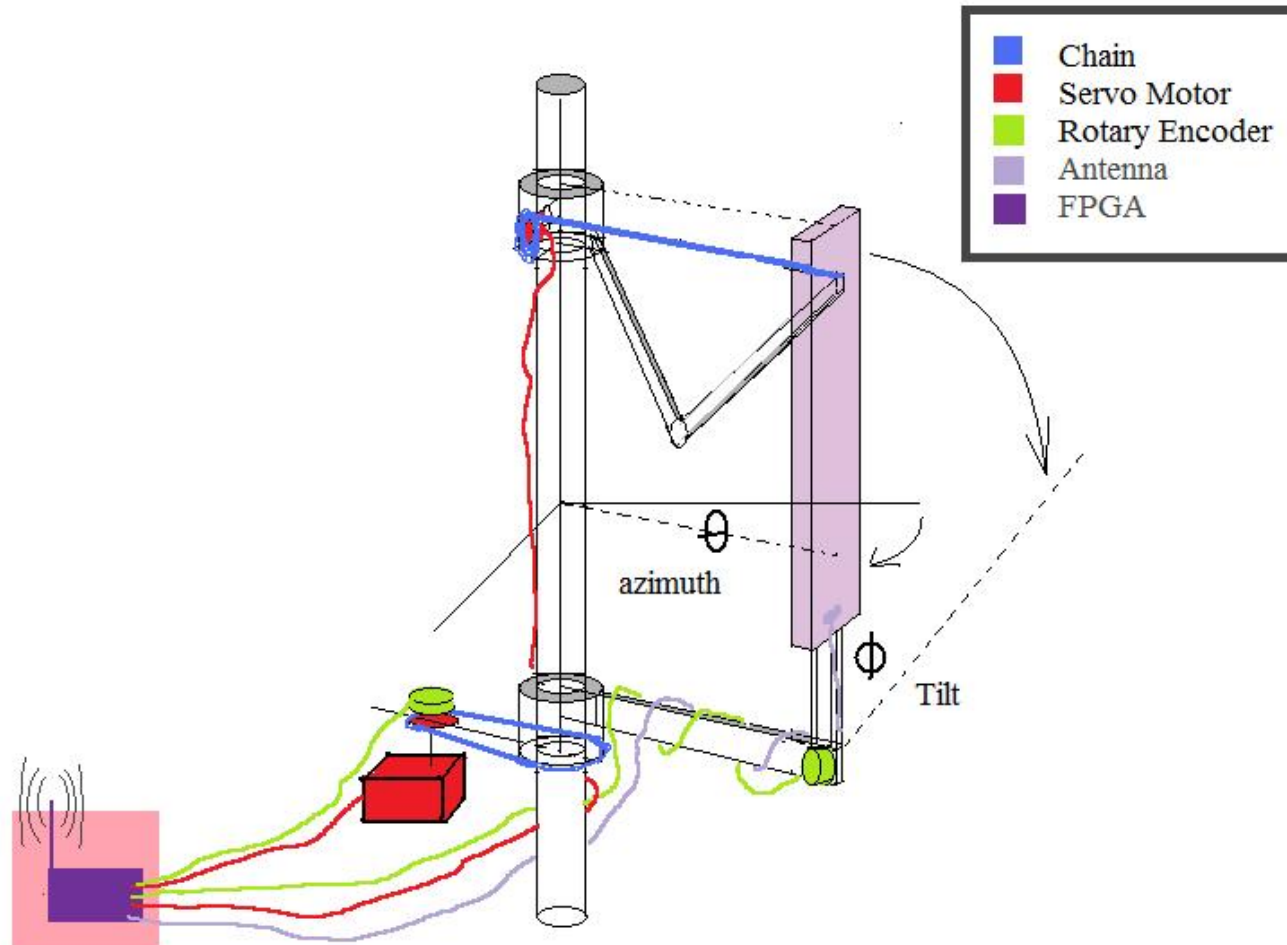

RAR Antenna Mount Model

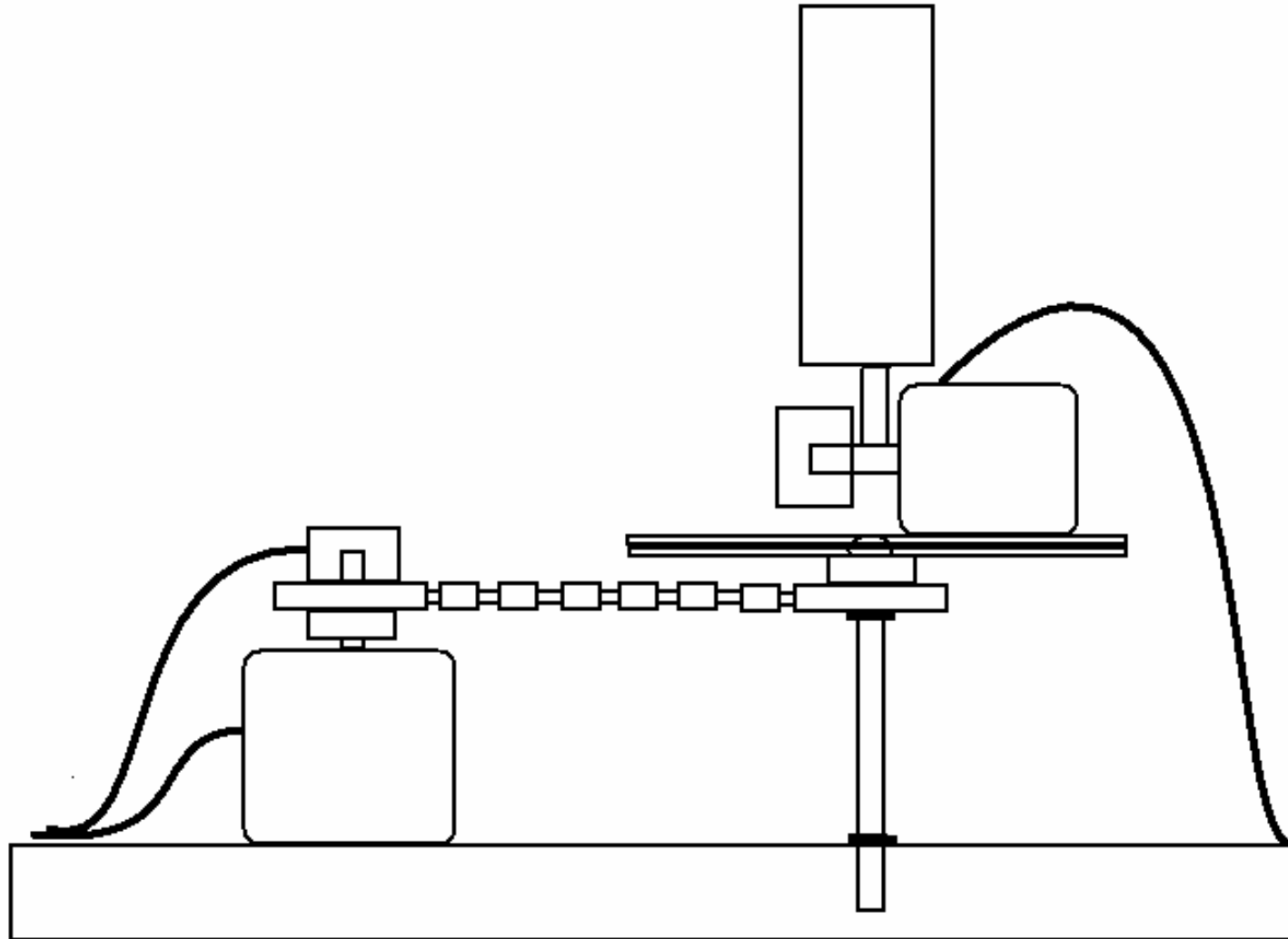

PROJECT DEMONSTRATION

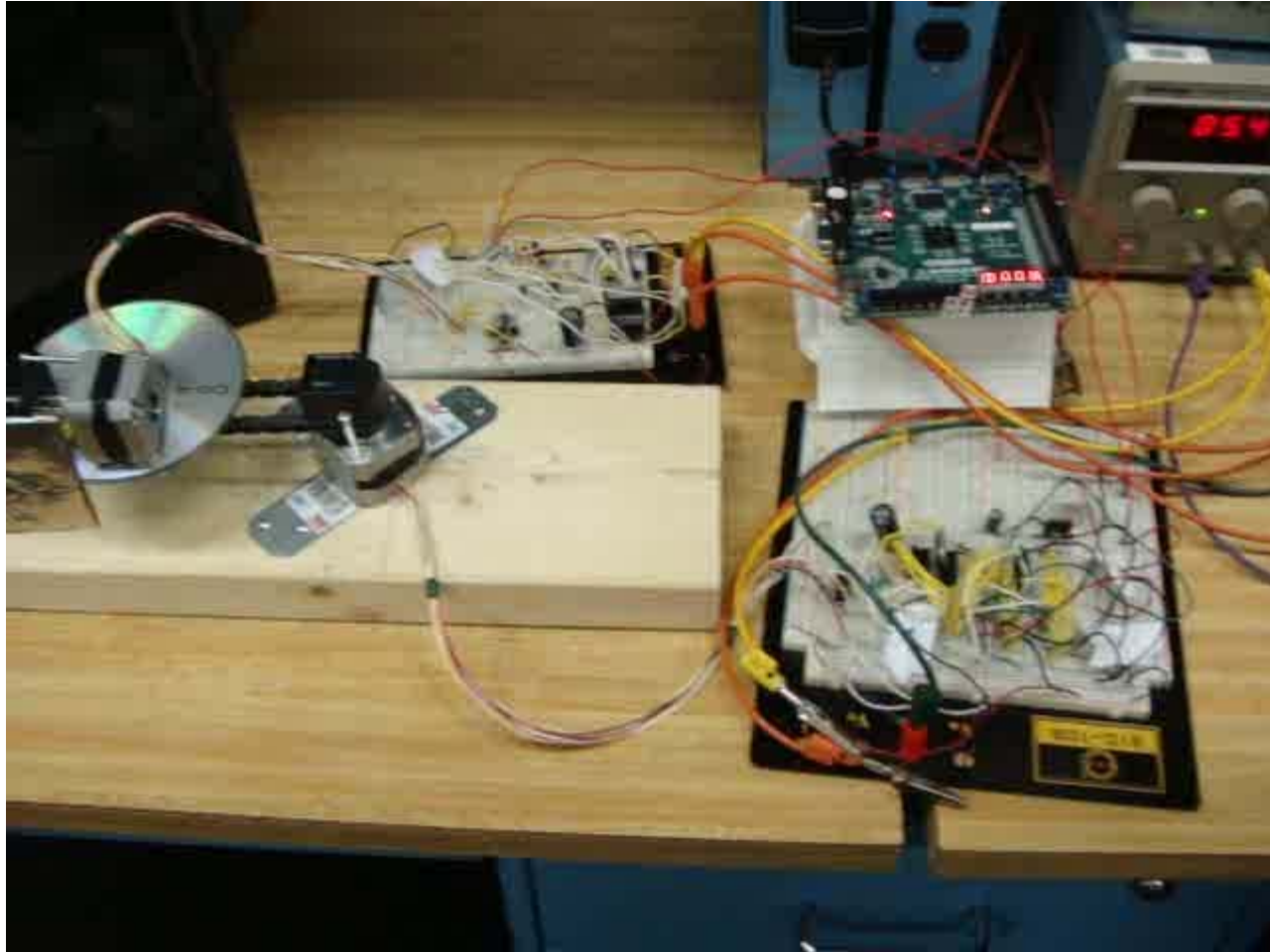

PERFORMANCE EVALUATION



- Developed to show compliance with design requirements

	Proposed	Attained	Real-world extrapolation
Response Time (max.)	1 minute	1.1 seconds	5seconds: Function of longer wires, step-up system
Speed	1 rev/minute	0.83 rev/minute	Same: Effects of larger motor, heavier antenna balanced by increased clock frequency
Accuracy	+ - 10 degrees	+ -0.9degrees	+ -0.3 degrees
Fail rate (max.)	10%	0%	Same
Cost	\$1500	\$500	About \$900

CONCLUSION



- ❑ We have succeeded in designing a remote antenna mount controller
- ❑ Our implemented system, though only a miniature model, demonstrates the desired antenna mount adjustment capability
- ❑ To complete the project we utilized knowledge from various subject areas such as: Electronics, Linear Controls, Digital System Design

SUGGESTED FUTURE PROJECTS

- ❑ Incorporate wireless transmission between user interface and control system
- ❑ Implement security system to prevent malignant parties from gaining control of antennae
- ❑ Include tracking system for automatic repositioning in case of wind

ACKNOWLEDGMENTS

- ❑ Our Adviser: Dr. John Anderson
- ❑ Dr. Clay Gloster
- ❑ Dr. Ahmed Rubaai
- ❑ Professors Glakpe, Vira, Warner, and Broome
- ❑ The Mechanical Engineering Department
- ❑ Dr. Mihai Dimian and Dr. Mohamed Chouikha

QUESTIONS

